



Date: 2020-04-02
 Customer: _____
 Contact: _____
 Submittee: J.C. Lavallée

**PERFORMANCE DATA SHEET
 NEMA PREMIUM NR CAN NEMA 12 - 12**

Catalogue #: **JMQP-37**

HP	kW	Voltage	S.F. @ 60Hz	EFF.	P.F.	Frame	Design	L.R. Amps
15	11,19	230/460	1,25	92,4%	0,81	254JM	B	116

60 Hz								
FLA							Code	F.L. RPM
208	230	416	460	480	575	600		
37,20	36,4	18,60	18,20	17,50	/	/		

50 Hz							
FLA			S.F. @ 50Hz	Efficiency	Power Factor	Code	F.L. RPM
190	380	415					
45,0	22,5	20,60					

Wgt. Lbs	PH	Duty	Insul. Class	Amb.	Elevation	Temp. Rise° C
297	3	Cont.	F	40°C	1000M (3300 Ft)	48

% Efficiency		% Power Factor		Torque		Winding Resist. Ω	Safe Cold Start (Secs)
Full Load:	92,4%	Full Load:	0,81	Full Load Ft/Lbs	44,5		
3/4 Load:	93,0%	3/4 Load:	0,80	Locked Rotor %	185		
1/2 Load:	92,7%	1/2 Load:	0,67	Break Down %	230		

Rotor Inertia Wk2 Lb-Ft2	Max Load Inertia Wk2 Lb-Ft2	Shaft Material	Frame Material	DE Bracket Type	ODE Bracket Type	Enclosure	NEMA Rating	Lead Wire Size
1,78	105	Standard	Cast Iron	Standard	Standard	TEFC	IP55	12AWG

Ball Bearings		Grease	Mount Type	Orientation	Paint	Sound Pressure @ 3FT	Sound Power
DE	ODE						
6309	6309	Mobil PolyrexEm	Rigid	Horizontal	Green	74	84

Inverter Duty.	Constant Torque Range	Variable Torque Range	Constant HP RPM
Motor meets MG1 parts 31.4.4.2	10:1	20:1	2700

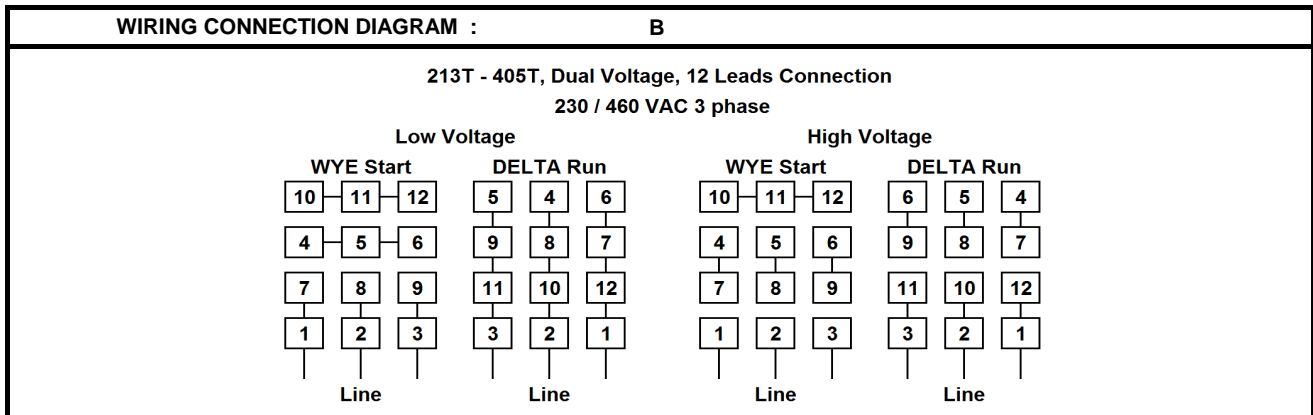

Date: 2020-04-02
 Customer: _____
 Contact: _____
 Submittee: J.C. Lavallée

Catalogue #: **JMQP-37**

NEMA PREMIUM NR CAN NEMA 12 - 12										
HP	VAC	RPM	Enclosure	Frame	Frequency	Design	Poles	LR Code Letter	Insulation Class	Temp. Rise °C
15	460	1770	TEFC	254JM	60	B	4	G	F	48
	0Hz	6Hz	15Hz	30Hz	45Hz	60Hz	75Hz	90Hz	105Hz	120Hz
Amps	18,2	18,2	18,2	18,2	18,2	18,2	18,2	18,2	18,2	18,2
RPM	0	177	442,5	885	1327,5	1770	2212,5	2655	3097,5	3540
Torq ft.lb	35,61	44,51	44,51	44,51	44,51	44,51	35,61	29,67	25,43	22,25
Peak Tq ft.lb	47,85	95,69	95,69	95,69	95,69	95,69	76,55	63,80	54,68	47,85
HP	0	1,5	3,8	7,5	11,3	15,0	15,0	15,0	15,0	15,0
	Locked Rotor	Pull-Up	Breakdown	Rated Load	Idle	Duty	S. F.	Ambient	Elevation	dBA @ 1M
Speed (RPM)	0,0	756	1440	1770	1800	Continuous	1,25	40°C	3300 ft	74
Current (Amps)	116,0	98,6	69,0	18,2	8,1	VFD Rating: Meets MG1 parts 31.4.4.2				
Torque (ft-lbs)	82,3	61,8	102,4	44,5	0,0	C.T.	10:1	V.T.	20:1	

Motor Speed Data

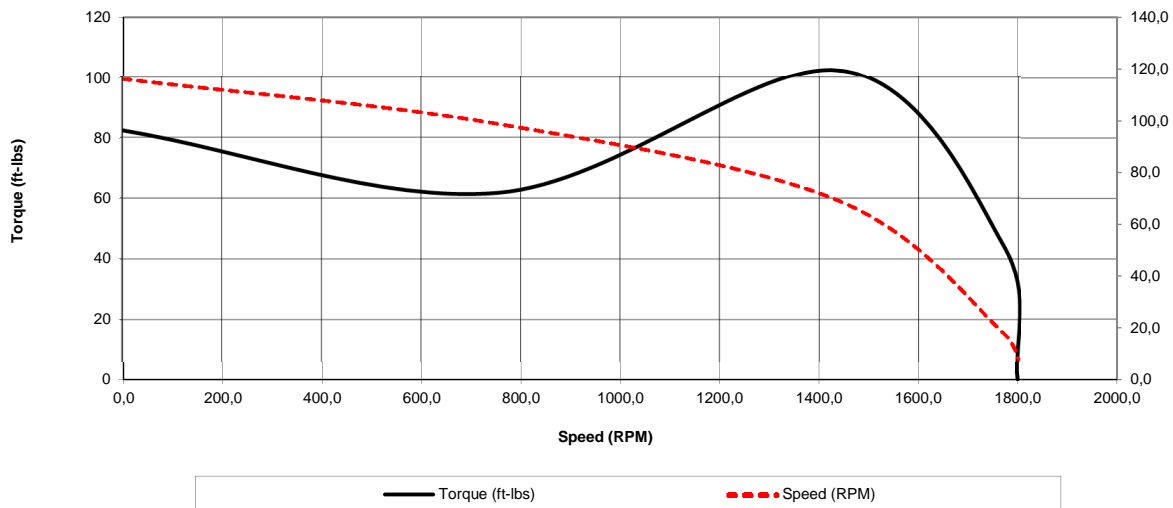

Motor Torque Capability vs RPM

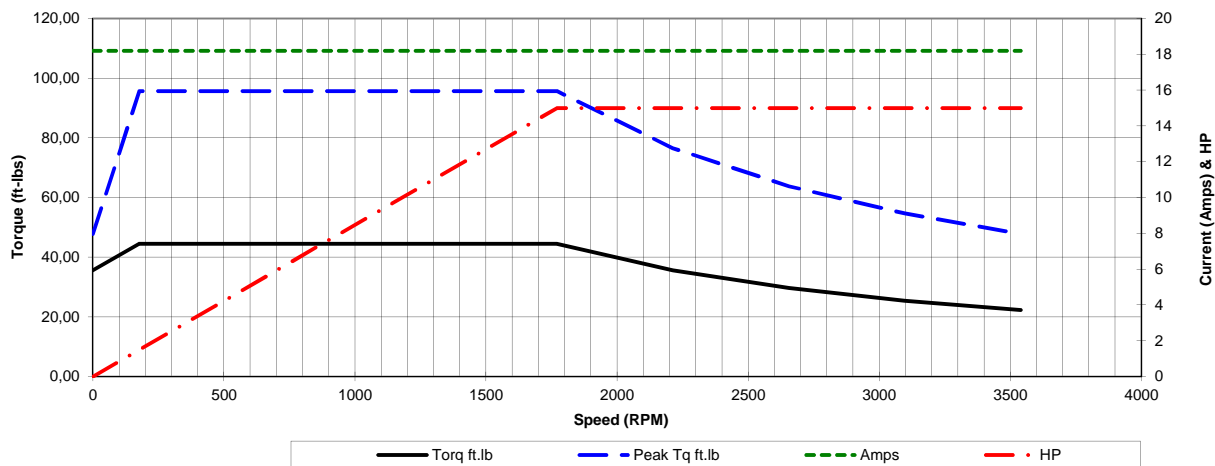



Date: 2020-04-02
 Customer: _____
 Contact: _____
 Submittee: J.C. Lavallée

Catalogue #: **JMQP-37**

NEMA PREMIUM NR CAN NEMA 12 - 12										
HP	VAC	RPM	Enclosure	Frame	Frequency	Design	Poles	LR Code Letter	Insulation Class	Temp. Rise °C
15	460	1770	TEFC	254JM	60	B	4	G	F	48

Load %	0%	25%	50%	75%	100%	125%	150%
Amps	8,10	8,65	11,20	14,50	18,20	23,06	27,74
Torq ft./lbs	0	10,77	21,69	32,68	43,81	55,10	66,53
RPM	0	1792,5	1785	1777,5	1770	1762,5	1755
Eff	0	90,81	92,70	93,00	92,40	92,40	92,40
PF	0	44,7	66,5	79,6	81	82,4	82,2

	Locked Rotor	Pull-Up	Breakdown	Rated Load	Idle	Duty	S. F.	Ambient	Elevation	dBA @ 1M
Speed (RPM)	0	756	1440	1770	1800	Continuous	1,25	40°C	3300 ft	74
Current (Amps)	116	98,6	69,0	18,2	8,1	VFD Rating: Meets MG1 parts 31.4.4.2				
Torque (ft.-lbs)	82,34	61,76	102,37	44,51	0,0	C.T.	10:1	V.T.	20:1	

